

NEC

Read this manual in its entirety before attempting to install or program the system.

1. COMMON EQUIPMENT

2. CONNECTING BLOCKS

3. PCBs

4. POWER UP

5. PHONES

6. TERMINAL/MODEM CONNECTIONS

7. MUSIC/PAGING RELAYS

8. POWER FAILURE

9. DUAL OPX/ASI

10. SPECIFICATIONS

11. PARTS LIST

ONYX™
II/III/IV

**Hardware Installation for
32 x 60, 56 x 120 and
72 x 180 Systems**

This manual has been developed by NEC America, Inc. It is intended for the use of its customers and service personnel, and should be read in its entirety before attempting to install or program the system. Any comments or suggestions for improving this manual would be appreciated. Forward your remarks to:

NEC America, Inc., Corporate Networks Group

4 Forest Parkway
Shelton, CT 06484
eng.nec.com

Nothing contained in this manual shall be deemed to be, and this manual does not constitute, a warranty of, or representation with respect to, any of the equipment covered. This manual is subject to change without notice and NEC America, Inc. has no obligation to provide any updates or corrections to this manual. Further, NEC America, Inc. also reserves the right, without prior notice, to make changes in equipment design or components as it deems appropriate. No representation is made that this manual is complete or accurate in all respects and NEC America, Inc. shall not be liable for any errors or omissions. In no event shall NEC America, Inc. be liable for any incidental or consequential damages in connection with the use of this manual. This document contains proprietary information that is protected by copyright. All rights are reserved. No part of this document may be photocopied or reproduced without prior written consent of NEC America, Inc.

©2002 by NEC America, Inc. All Rights Reserved.
Printed in U.S.A.

1. INSTALLING THE COMMON EQUIPMENT

1. Mount a plywood backboard for the CEUs at a convenient working height.
2. Using the CEU as a guide, mark the location for the CEU mounting screws. The CEUs must be 6-8" apart.
3. Install screws and hang CEUs. Tighten mounting screws.
4. Install connecting blocks for stations and lines. Connect cables as shown. Refer to Section 2, Connecting Blocks, Table 1 for station cutdown. Refer to Tables 2, 3, 4 and 5 for line cutdown.

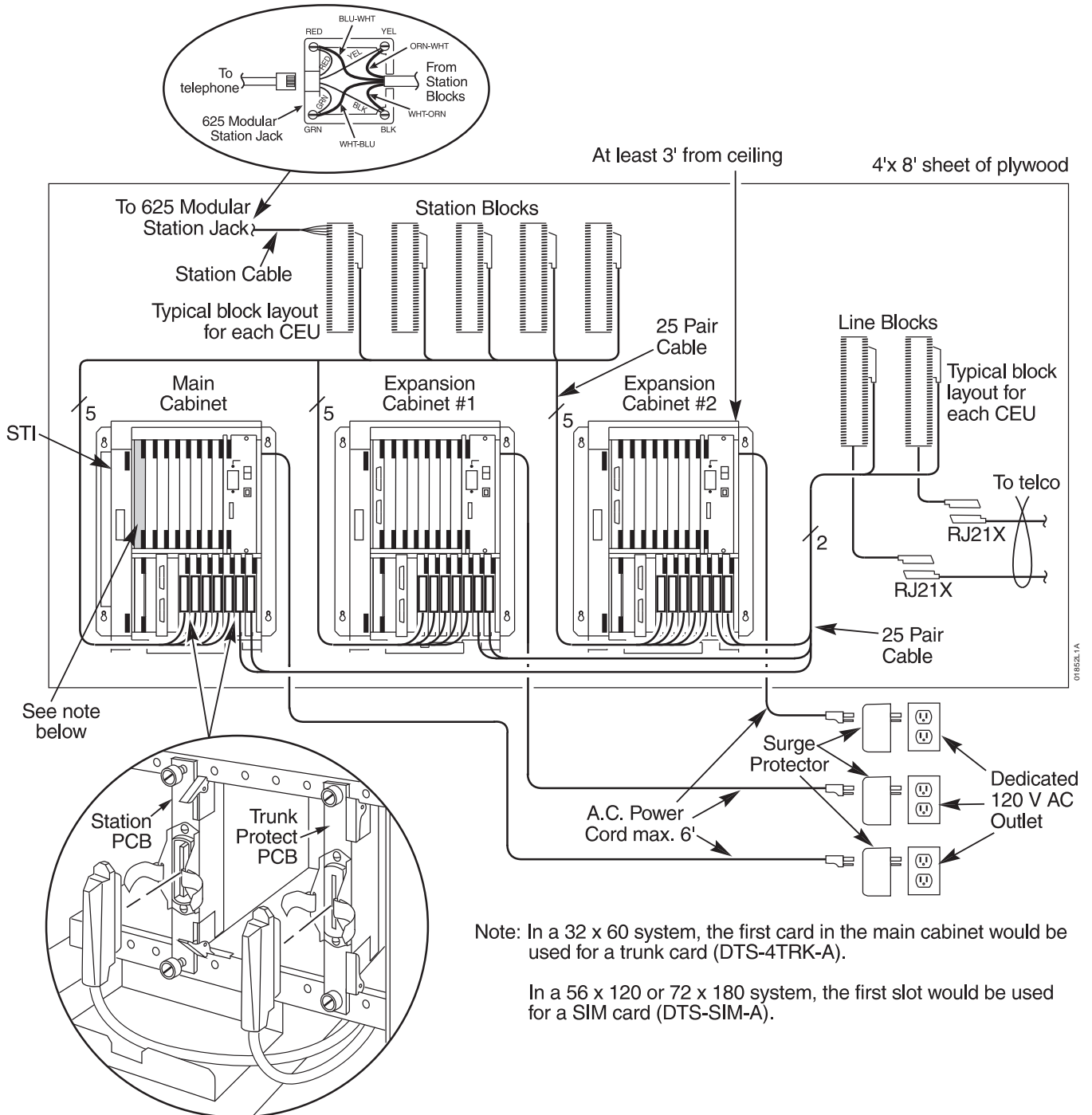

Detail A

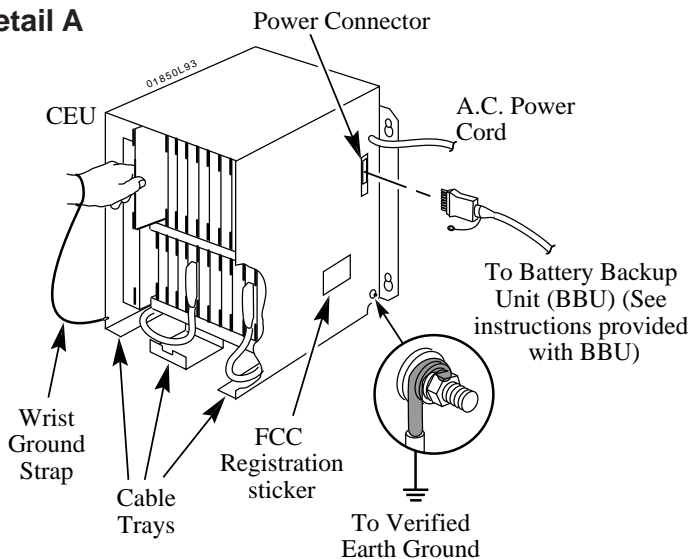

Note: Install all DSS consoles in the Main Cabinet.

5. Ground each CEU separately to a known earth ground.
6. Plug a power supply into each CEU. Refer to Section 3, Where the PCBs Plug In, when necessary.
7. Plug all PCBs into designated slots in each CEU. Refer to Section 3, Where the PCBs Plug In, when necessary.

Note: Wear a grounded wrist strap when installing or removing PCBs (see Detail A).

8. Power down the CEU when installing or removing the following PCBs:
 DTS-HCPU-
 DTS-SIM-
 DTS-COM-
 DTS-MEM-
 DTS-VAU- or OPA/VAU-
 DTS-MLU-
 DTS-Software Cartridges

CAUTION: The power cord **must** be unplugged before removing or installing the power supply.

9. The following PCBs can be installed or removed **without** powering down the system:

DTS-12SCU-
 DTS-4LNU-
 DTS-4TRK-
 DTS-TRPT-

10. Power down the CEU when installing or removing the software cartridges.

11. Place the FCC Registration sticker packaged with the software cartridge on the right side of the CEU.

12. For power and signaling to a DTS-STI unit, connect the DTS-STI to the last port pair on a DTS-12SCU PCB.

Note: Only port pairs from the first four DTS-12SCU PCBs in the Main CEU can be used for STIs.

13. For 56 x 120 systems, connect CEUs by installing one System Interlink Cable. For 72 x 180 systems, connect CEU's by installing three System Interlink Cables.

**Detail B
 DTS-SIM-A Connections**

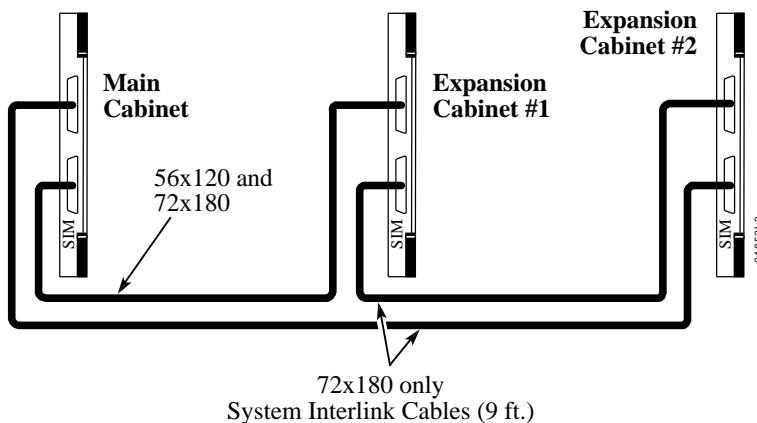

2. CONNECTING BLOCKS

Table 1. Station Assignments

| 25-PAIR CABLE | | | STATION (PORT) CUTDOWN | | | | | |
|---------------|-------------|------------|------------------------|-----------|-----------|-----------|-----------|-----------|
| CONN PIN | BLOCK TERM. | COLOR CODE | FUNC. | 12 SCU #1 | 12 SCU #2 | 12 SCU #3 | 12 SCU #4 | 12 SCU #5 |
| 26 | 1 | WHT-BLU | TT | 300 (00) | 312 (12) | 324 (24) | 336 (36) | 348 (48) |
| 1 | 2 | BLU-WHT | TR | 360 (60) | 372 (72) | 384 (84) | 396 (96) | 408 (108) |
| 27 | 3 | WHT-ORN | RT | 420 (120) | 432 (132) | 444 (144) | 456 (156) | 468 (168) |
| 2 | 4 | ORN-WHT | RR | | | | | |
| 28 | 5 | WHT-GRN | TT | 301 (01) | 313 (13) | 325 (25) | 337 (37) | 349 (49) |
| 3 | 6 | GRN-WHT | TR | 361 (61) | 373 (73) | 385 (85) | 397 (97) | 409 (109) |
| 29 | 7 | WHT-BRN | RT | 421 (121) | 433 (133) | 445 (145) | 457 (157) | 469 (169) |
| 4 | 8 | BRN-WHT | RR | | | | | |
| 30 | 9 | WHT-SLT | TT | 302 (02) | 314 (14) | 326 (26) | 338 (38) | 350 (50) |
| 5 | 10 | SLT-WHT | TR | 362 (62) | 374 (74) | 386 (86) | 398 (98) | 410 (110) |
| 31 | 11 | RED-BLU | RT | 422 (122) | 434 (134) | 446 (146) | 458 (158) | 470 (170) |
| 6 | 12 | BLU-RED | RR | | | | | |
| 32 | 13 | RED-ORN | TT | 303 (03) | 315 (15) | 327 (27) | 339 (39) | 351 (51) |
| 7 | 14 | ORN-RED | TR | 363 (63) | 375 (75) | 387 (87) | 399 (99) | 411 (111) |
| 33 | 15 | RED-GRN | RT | 423 (123) | 435 (135) | 447 (147) | 459 (159) | 471 (171) |
| 8 | 16 | GRN-RED | RR | | | | | |
| 34 | 17 | RED-BRN | TT | 304 (04) | 316 (16) | 328 (28) | 340 (40) | 352 (52) |
| 9 | 18 | BRN-RED | TR | 364 (64) | 376 (76) | 388 (88) | 400 (100) | 412 (112) |
| 35 | 19 | RED-SLT | RT | 424 (124) | 436 (136) | 448 (148) | 460 (160) | 472 (172) |
| 10 | 20 | SLT-RED | RR | | | | | |
| 36 | 21 | BLK-BLU | TT | 305 (05) | 317 (17) | 329 (29) | 341 (41) | 353 (53) |
| 11 | 22 | BLU-BLK | TR | 365 (65) | 377 (77) | 389 (89) | 401 (101) | 413 (113) |
| 37 | 23 | BLK-ORN | RT | 425 (125) | 437 (137) | 449 (149) | 461 (161) | 473 (173) |
| 12 | 24 | ORN-BLK | RR | | | | | |
| 38 | 25 | BLK-GRN | TT | 306 (06) | 318 (18) | 330 (30) | 342 (42) | 354 (54) |
| 13 | 26 | GRN-BLK | TR | 366 (66) | 378 (78) | 390 (90) | 402 (102) | 414 (114) |
| 39 | 27 | BLK-BRN | RT | 426 (126) | 438 (138) | 450 (150) | 462 (162) | 474 (174) |
| 14 | 28 | BRN-BLK | RR | | | | | |
| 40 | 29 | BLK-SLT | TT | 307 (07) | 319 (19) | 331 (31) | 343 (43) | 355 (55) |
| 15 | 30 | SLT-BLK | TR | 367 (67) | 379 (79) | 391 (91) | 403 (103) | 415 (115) |
| 41 | 31 | YEL-BLU | RT | 427 (127) | 439 (139) | 451 (151) | 463 (163) | 475 (175) |
| 16 | 32 | BLU-YEL | RR | | | | | |
| 42 | 33 | YEL-ORN | TT | 308 (08) | 320 (20) | 332 (32) | 344 (44) | 356 (56) |
| 17 | 34 | ORN-YEL | TR | 368 (68) | 380 (80) | 392 (92) | 404 (104) | 416 (116) |
| 43 | 35 | YEL-GRN | RT | 428 (128) | 440 (140) | 452 (152) | 464 (164) | 476 (176) |
| 18 | 36 | GRN-YEL | RR | | | | | |
| 44 | 37 | YEL-BRN | TT | 309 (09) | 321 (21) | 333 (33) | 345 (45) | 357 (57) |
| 19 | 38 | BRN-YEL | TR | 369 (69) | 381 (81) | 393 (93) | 405 (105) | 417 (117) |
| 45 | 39 | YEL-SLT | RT | 429 (129) | 441 (141) | 453 (153) | 465 (165) | 477 (117) |
| 20 | 40 | SLT-YEL | RR | | | | | |
| 46 | 41 | VIO-BLU | TT | 310 (10) | 322 (22) | 334 (34) | 346 (46) | 358 (58) |
| 21 | 42 | BLU-VIO | TR | 370 (70) | 382 (82) | 394 (94) | 406 (106) | 418 (118) |
| 47 | 43 | VIO-ORN | RT | 430 (130) | 442 (142) | 454 (154) | 466 (166) | 478 (178) |
| 22 | 44 | ORN-VIO | RR | | | | | |
| 48 | 45 | VIO-GRN | TT | 311 (11) | 323 (23) | 335 (35) | 347 (47) | 359 (59) |
| 23 | 46 | GRN-VIO | TR | 371 (71) | 383 (83) | 395 (95) | 407 (107) | 419 (119) |
| 49 | 47 | VIO-BRN | RT | 431 (131) | 443 (143) | 455 (155) | 467 (167) | 479 (179) |
| 24 | 48 | BRN-VIO | RR | | | | | |
| 50 | 49 | VIO-SLT | N/C | | | | | |
| 25 | 50 | SLT-VIO | N/C | | | | | |

N1852-3

= Use with 32 x 60 system (Main Cabinet)

= Use with 56 x 120 system (Expansion Cabinet #1)

= Use with 72 x 180 system (Expansion Cabinet #2)

Table 2. Main Cabinet Line Assignments 32 x 60

| 25-PAIR CABLE | | DTS-TRPT-A #1 (LINES 01-16) | | | | DTS-TRPT-A #2 (LINES 17-32) | | | |
|--|--|--|----------|----------------------------------|--|--|----------|----------------------------------|--|
| CONN. PIN | COLOR CODE | CO (EXT.) PORT | 4LNU PCB | BLOCK TERM. | FUNC. | CO (EXT.) PORT | 4LNU PCB | BLOCK TERM. | FUNC. |
| 26 1 | WHT-BLU BLU-WHT | 1-(396) 96 | 1 | 1 2 | T R | 17-(412) 112 | 5 | 1 2 | T R |
| 27 2 | WHT-ORN ORN-WHT | 2-(397) 97 | | 3 4 | T R | 18-(413) 113 | | 3 4 | T R |
| 28 3 | WHT-GRN GRN-WHT | 3-(398) 98 | | 5 6 | T R | 19-(414) 114 | | 5 6 | T R |
| 29 4 | WHT-BRN BRN-WHT | 4-(399) 99 | | 7 8 | T R | 20-(415) 115 | | 7 8 | T R |
| 30 5 | WHT-SLT SLT-WHT | 5-(400) 100 | 2 | 9 10 | T R | 21-(416) 116 | 6 | 9 10 | T R |
| 31 6 | RED-BLU BLU-RED | 6-(401) 101 | | 11 12 | T R | 22-(417) 117 | | 11 12 | T R |
| 32 7 | RED-ORN ORN-RED | 7-(402) 102 | | 13 14 | T R | 23-(418) 118 | | 13 14 | T R |
| 33 8 | RED-GRN GRN-RED | 8-(403) 103 | | 15 16 | T R | 24-(419) 119 | | 15 16 | T R |
| 34 9 | RED-BRN BRN-RED | 9-(404) 104 | 3 | 17 18 | T R | 25-(420) 120 | 7 | 17 18 | T R |
| 35 10 | RED-SLT SLT-RED | 10-(405) 105 | | 19 20 | T R | 26-(421) 121 | | 19 20 | T R |
| 36 11 | BLK-BLU BLU-BLK | 11-(406) 106 | | 21 22 | T R | 27-(422) 122 | | 21 22 | T R |
| 37 12 | BLK-ORN ORN-BLK | 12-(407) 107 | | 23 24 | T R | 28-(423) 123 | | 23 24 | T R |
| 38 13 | BLK-GRN GRN-BLK | 13-(408) 108 | 4 | 25 26 | T R | 29-(424) 124 | 8 | 25 26 | T R |
| 39 14 | BLK-BRN BRN-BLK | 14-(409) 109 | | 27 28 | T R | 30-(425) 125 | | 27 28 | T R |
| 40 15 | BLK-SLT SLT-BLK | 15-(410) 110 | | 29 30 | T R | 31-(426) 126 | | 29 30 | T R |
| 41 16 | YEL-BLU BLU-YEL | 16-(411) 111 | | 31 32 | T R | 32-(427) 127 | | 31 32 | T R |
| 42 17 43 18 44 19 45 20 | YEL-ORN ORN-YEL YEL-GRN GRN-YEL YEL-BRN BRN-YEL YEL-SLT SLT-YEL | Block Terminals 33-40 are Not Used | | | | | | | |
| 46 21 47 22 | VIO-BLU BLU-VIO VIO-ORN ORN-VIO | Ext. Control Relay #1 Ext. Control Relay #2 | | 41 42 43 44 | CT1 CR1 CT2 CR2 | Ext. Control Relay #3 Ext. Control Relay #4 | | 41 42 43 44 | CT3 CR3 CT4 CR4 |
| 48 23 49 24 50 25 | VIO-GRN GRN-VIO VIO-BRN BRN-VIO VIO-SLT SLT-VIO | Power Failure Relay #1 Input Out to Power Failure Set Out to Line Block | | 45 46 47 48 49 50 | Rg In Tp In Rg Cut Tp Cut Rg Sys Tp Sys | Power Failure Relay #2 Input Out to Power Failure Set Out to Line Block | | 45 46 47 48 49 50 | Rg In Tp In Rg Cut Tp Cut Rg Sys Tp Sys |

N1892-4

2. CONNECTING BLOCKS (Cont'd)

Table 3. Main Cabinet Line Assignments 56 x 120, 72 x 180

| 25-PAIR CABLE | | DTS-TRPT-A #1 (LINES 01-12) | | | | DTS-TRPT-A #2 (LINES 13-28) | | | | | | | |
|--|--|-----------------------------|----------|-------------|-------|--|----------|--|--|--|---|--|--|
| CONN. PIN | COLOR CODE | CO (EXT.) PORT | 4LNU PCB | BLOCK TERM. | FUNC. | CO (EXT.) PORT | 4LNU PCB | BLOCK TERM. | FUNC. | | | | |
| 26 1 27 2 28 3 29 4 | WHT-BLU BLU-WHT WHT-ORN ORN-WHT WHT-GRN GRN-WHT WHT-BRN BRN-WHT | Used For SIM-A | | | | 13-(492) 192 14-(493) 193 15-(494) 194 16-(495) 195 | 4 | 1 2 3 4 5 6 7 8 | T R T R T R T R | | | | |
| 30 5 31 6 32 7 33 8 | WHT-SLT SLT-WHT RED-BLU BLU-RED RED-ORN ORN-RED RED-GRN GRN-RED | | | | | 1-(480) (A) 180 2-(481) (A) 181 3-(482) (A) 182 4-(483) (A) 183 | 1 | 9 10 11 12 13 14 15 16 | T R T R T R T R | 17-(496) 196 18-(497) 197 19-(498) 198 20-(499) 199 | 5 | 9 10 11 12 13 14 15 16 | T R T R T R T R |
| 34 9 35 10 36 11 37 12 | RED-BRN BRN-RED RED-SLT SLT-RED BLK-BLU BLU-BLK BLK-ORN ORN-BLK | | | | | 5-(484) 184 6-(485) 185 7-(486) 186 8-(487) 187 | 2 | 17 18 19 20 21 22 23 24 | T R T R T R T R | 21-(500) 200 22-(501) 201 23-(502) 202 24-(503) 203 | 6 | 17 18 19 20 21 22 23 24 | T R T R T R T R |
| 38 13 39 14 40 15 41 16 | BLK-GRN GRN-BLK BLK-BRN BRN-BLK BLK-SLT SLT-BLK YEL-BLU BLU-YEL | | | | | 9-(488) 188 10-(489) 189 11-(490) 190 12-(491) 191 | 3 | 25 26 27 28 29 30 31 32 | T R T R T R T R | 25-(504) 204 26-(505) 205 27-(506) 206 28-(507) 207 | 7 | 25 26 27 28 29 30 31 32 | T R T R T R T R |
| 42 17 43 18 44 19 45 20 | YEL-ORN ORN-YEL YEL-GRN GRN-YEL YEL-BRN BRN-YEL YEL-SLT SLT-YEL | | | | | Block Terminals 33-40 are Not Used | | | | | | | |
| 46 21 47 22 | VIO-BLU BLU-VIO VIO-ORN ORN-VIO | | | | | Ext. Control Relay #1 Ext. Control Relay #2 | | 41 42 43 44 | CT1 CR1 CT2 CR2 | Ext. Control Relay #3 Ext. Control Relay #4 | | 41 42 43 44 | CT3 CR3 CT4 CR4 |
| 48 23 49 24 50 25 | VIO-GRN GRN-VIO VIO-BRN BRN-VIO VIO-SLT SLT-VIO | | | | | Power Failure Relay #1 Input Out to Power Failure Set Out to Line Block | | 45 46 47 48 49 50 | Rg In Tp In Rg Cut Tp Cut Rg Sys Tp Sys | Power Failure Relay #2 Input Out to Power Failure Set Out to Line Block | | 45 46 47 48 49 50 | Rg In Tp In Rg Cut Tp Cut Rg Sys Tp Sys |

A = These analog trunk circuits are not recognized with a Single Port T1 card.

N1852-5

Table 4. Expansion Cabinet #1 Line Assignments 56 x 120, 72 x 180

| 25-PAIR CABLE | | DTS-TRPT-A #3 (LINES 29-44) | | | | DTS-TRPT-A #4 (LINES 45-56) | | | |
|--|--|--|----------|--|--|--|----------|--|--|
| CONN. PIN | COLOR CODE | CO (EXT.) PORT | 4LNU PCB | BLOCK TERM. | FUNC. | CO (EXT.) PORT | 4LNU PCB | BLOCK TERM. | FUNC. |
| 26 1 27 2 28 3 29 4 | WHT-BLU BLU-WHT WHT-ORN ORN-WHT WHT-GRN GRN-WHT WHT-BRN BRN-WHT | Used for SIM-A | | | | 41-(520) (B) 220 42-(521) (B) 221 43-(522) (B) 222 44-(523) (B) 223 | 11 | 1 2 3 4 5 6 7 8 | T R T R T R T R |
| 30 5 31 6 32 7 33 8 | WHT-SLT SLT-WHT RED-BLU BLU-RED RED-ORN ORN-RED RED-GRN GRN-RED | 29-(508) (B) 208 30-(509) (B) 209 31-(510) (B) 210 32-(511) (B) 211 | 8 | 9 10 11 12 13 14 15 16 | T R T R T R T R | 45-(524) (B) 224 46-(525) (B) 225 47-(526) (B) 226 48-(527) (B) 227 | 12 | 9 10 11 12 13 14 15 16 | T R T R T R T R |
| 34 9 35 10 36 11 37 12 | RED-BRN BRN-RED RED-SLT SLT-RED BLK-BLU BLU-BLK BLK-ORN ORN-BLK | 33-(512) (B) 212 34-(513) (B) 213 35-(514) (B) 214 36-(515) (B) 215 | 9 | 17 18 19 20 21 22 23 24 | T R T R T R T R | 49-(528) (B) 228 50-(529) (B) 229 51-(530) (B) 230 52-(531) (B) 231 | 13 | 17 18 19 20 21 22 23 24 | T R T R T R T R |
| 38 13 39 14 40 15 41 16 | BLK-GRN GRN-BLK BLK-BRN BRN-BLK BLK-SLT SLT-BLK YEL-BLU BLU-YEL | 37-(516) (B) 216 38-(517) (B) 217 39-(518) (B) 218 40-(519) (B) 219 | 10 | 25 26 27 28 29 30 31 32 | T R T R T R T R | 53-(532) (A) 232 54-(533) (A) 233 55-(534) (A) 234 56-(535) (A) 235 | 14 | 25 26 27 28 29 30 31 32 | T R T R T R T R |
| 42 17 43 18 44 19 45 20 46 21 47 22 | YEL-ORN ORN-YEL YEL-GRN GRN-YEL YEL-BRN BRN-YEL YEL-SLT SLT-YEL VIO-BLU BLU-VIO VIO-ORN ORN-VIO | Block Terminals 33-44 are Not Used | | | | | | | |
| 48 23 49 24 50 25 | VIO-GRN GRN-VIO VIO-BRN BRN-VIO VIO-SLT SLT-VIO | Power Failure Relay #3 Input Out to Power Failure Set Out to Line Block | | 45 46 47 48 49 50 | Rg In Tp In Rg Cut Tp Cut Rg Sys Tp Sys | Power Failure Relay #4 Input Out to Power Failure Set Out to Line Block | | 45 46 47 48 49 50 | Rg In Tp In Rg Cut Tp Cut Rg Sys Tp Sys |

A = These analog trunk circuits are not recognized with a Single Port T1 card.
 B = In addition to circuits not recognized with a Single Port T1 card, these analog trunk circuits are also not recognized with a Dual Port T1 card.

NT1852-6

2. CONNECTING BLOCKS (Cont'd)

Table 5. Expansion Cabinet #2 Line Assignments 72 x 180

| 25-PAIR CABLE | | DTS-TRPT-A #5 (LINES 57-68) | | | | DTS-TRPT-A #6 (LINES 69-72) | | | | | | | | |
|--|--|------------------------------------|----------|-------------|----------------|---------------------------------|----------|----------------|----------|--------|----------|--|--|--|
| CONN. PIN | COLOR CODE | CO (EXT.) PORT | 4LNU PCB | BLOCK TERM. | FUNC. | CO (EXT.) PORT | 4LNU PCB | BLOCK TERM. | FUNC. | | | | | |
| 26 1 27 2 28 3 29 4 | WHT-BLU BLU-WHT WHT-ORN ORN-WHT WHT-GRN GRN-WHT WHT-BRN BRN-WHT | Used for SIM-A | | | | 69-(548) (A) 248 | 18 | 1 2 | T R | | | | | |
| | | | | | | 70-(549) (A) 249 | | 3 4 | T R | | | | | |
| | | | | | | 71-(550) (A) 250 | | 5 6 | T R | | | | | |
| | | | | | | 72-(551) (A) 251 | | 7 8 | T R | | | | | |
| 30 5 31 6 32 7 33 8 | WHT-SLT SLT-WHT RED-BLU BLU-RED RED-ORN ORN-RED RED-GRN GRN-RED | | | | | 57-(536) (A) 236 | | 15 | 9 10 | T R | Not Used | | | |
| | | | | | | 58-(537) (A) 237 | | | 11 12 | T R | | | | |
| | | | | | | 59-(538) (A) 238 | | | 13 14 | T R | | | | |
| | | | | | | 60-(539) (A) 239 | | | 15 16 | T R | | | | |
| 34 9 35 10 36 11 37 12 | RED-BRN BRN-RED RED-SLT SLT-RED BLK-BLU BLU-BLK BLK-ORN ORN-BLK | 61-(540) (A) 240 | 16 | 17 18 | T R | Not Used | | | | | | | | |
| | | 62-(541) (A) 241 | | 19 20 | T R | | | | | | | | | |
| | | 63-(542) (A) 242 | | 21 22 | T R | | | | | | | | | |
| | | 64-(543) (A) 243 | | 23 24 | T R | | | | | | | | | |
| 38 13 39 14 40 15 41 16 | BLK-GRN GRN-BLK BLK-BRN BRN-BLK BLK-SLT SLT-BLK YEL-BLU BLU-YEL | 65-(544) (A) 244 | | 17 | 25 26 | | | | | T R | Not Used | | | |
| | | 66-(545) (A) 245 | | | 27 28 | | | | | T R | | | | |
| | | 67-(546) (A) 246 | | | 29 30 | | | | | T R | | | | |
| | | 68-(547) (A) 247 | | | 31 32 | | | | | T R | | | | |
| 42 17 43 18 44 19 45 20 46 21 47 22 | YEL-ORN ORN-YEL YEL-GRN GRN-YEL YEL-BRN BRN-YEL YEL-SLT SLT-YEL VIO-BLU BLU-VIO VIO-ORN ORN-VIO | Block Terminals 33-44 are Not Used | | | | | | | | | | | | |
| 48 23 49 24 50 25 | VIO-GRN GRN-VIO VIO-BRN BRN-VIO VIO-SLT SLT-VIO | Power Failure Relay #5 Input | 45 46 | | Rg In Tp In | Power Failure Relay #6 Input | 45 46 | Rg In Tp In | | | | | | |
| | | Out to Power | 47 | | Rg Cut | Out to Power | 47 | Rg Cut | | | | | | |
| | | Failure Set | 48 | | Tp Cut | Failure Set | 48 | Tp Cut | | | | | | |
| | | Out to Line | 49 | Rg Sys | Out to Line | 49 | Rg Sys | | | | | | | |
| | | Block | 50 | Tp Sys | Block | 50 | Tp Sys | | | | | | | |

A = These analog trunk circuits are not recognized with a Single Port T1 card.

N1852-7

3. WHERE THE PCBs PLUG IN

For 56 x 120, 72 x 180 systems

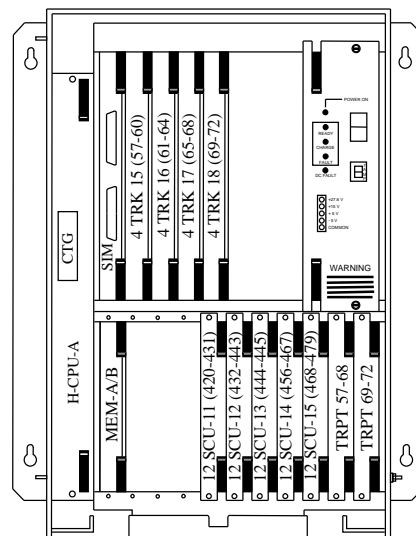
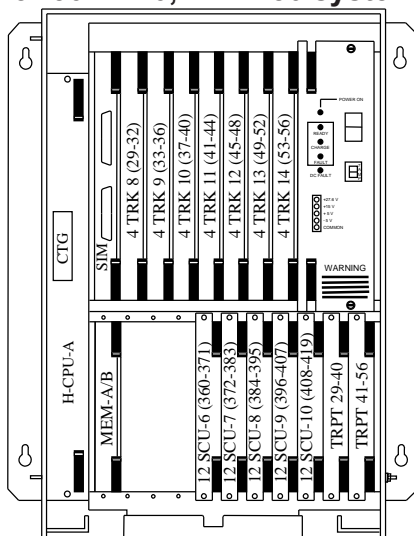
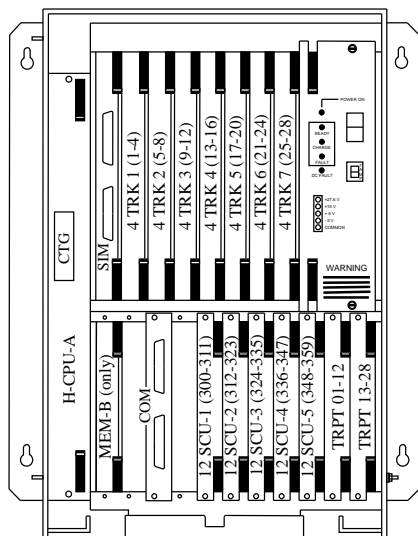

3.

DTS-CEU-D (P/N 88100D)

Common Equipment Unit

- One required, three max.
- For 32 x 60 system, max. configuration is 32 lines by 60 extensions.
- For 56 x 120 or 72 x 180 systems, max. configuration of the first two CEUs is 28 lines by 60 extensions.
- For 72 x 180 system, max. configuration of the third CEU is 16 lines by 60 extensions.

Note: Each CEU requires one power supply.

DTS-PSU-A

Power Supply 'A' (P/N 88105)

or

Power Supply 'D' (P/N 88108)

- Use when a CEU requires Battery Backup (P/N 88107).

Power Supply 'B' (P/N 88104)

- Use when a CEU has 36 stations or less.

Power Supply 'C' (P/N 88106A)

- Use when a CEU has more than 36 stations.

DTS-HCPU-A (P/N 88340)

Central Processing Unit

- One required per CEU.
- Controls CEU hardware and software components.

For 32 x 60 systems

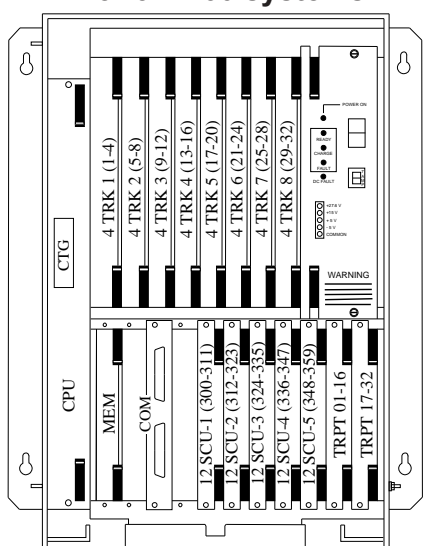

DTS-COM-A (P/N 88125/A)

Communications Port PCB

- One per system maximum.
- Required to connect a programming terminal, modem, or personal computer to the system.
- Install in main CEU only.

DCX-12SCU-A (P/N 88120)

Station PCB

- 32 x 60 system - 5 max.
- 56 x 120 and 72 x 180 systems - 15 max - 5 per CEU.
- Provides 12 station circuits.

DTS-STI-B PCB (P/N 88147)

Special Trunk Interface (STI)

- Each DTS-STI requires two DTS-12SCU ports. The first four DTS-12SCUs in the Main CEU provide DTS-STI interface.
- Two max. per 32 x 60 system (with four DTS-12SCU PCBs in the CEU).
- Four max. per 56 x 120 and 72 x 180 systems (with four DTS-12SCU PCBs in the Main CEU installed).
- Provides eight OPX/DID circuits and seven tie line circuits.
- Provides two dedicated DTMF receivers.

(Continued on page 8)

- Provides 12 handsfree circuits
- Provides Intercom ringing

DTS-SIM-A PCB (P/N 88275)

(See Detail A, page 9)

- One required per CEU for 56 x 120 and 72 x 180 systems only (see chart Detail E, page 9).

Software Cartridges

- Contains operating software for each CEU (see chart Detail E, page 9).

3. WHERE THE PCBs PLUG IN (Cont'd)

Note: Refer to the DTS-STI Installation and Programming Manual for installation procedures (P/N N1850STI02).

Note: Each CEU requires one DTS-MEM PCB. The Main CEU must have a DTS-MEM-B PCB installed. Expansion CEU's allow either DTS-MEM-A or DTS-MEM-B PCBs.

DTS-MEM-A (P/N 88130) Memory PCB

(See Detail B, page 9)

- Two maximum.
- Install only in the expansion CEU's of 56 x 120 and 72 x 180 systems.

DTS-MEM-B (P/N 88132) Memory PCB

(See Detail C, page 9)

- One required in main CEU of 32 x 60, 56 x 120 or 72 x 180 systems.
- Three maximum.
- Install in any CEU.
- Use when any of the following features are required:
 - Automatic Route Selection
 - Full Directory Dialing
 - 438 SMDR record buffer
 - Station Display messaging
 - 102 Speed Dial Blocks
 - Required for Data Base Upload and Download

DTS-TRPT-A (P/N 88135) Trunk Protect PCB

- Two max. per CEU.
- Connects 16 lines from telco to line/trunk PCB's.
- Provides line current and voltage protection.
- Provides relays for:
 - Power Failure Cut-Through
 - External Zone Paging (Main CEU only)
 - Loud Bells - Main CEU only)

DTS 4LNU-B (P/N 88110B) Line Circuit PCB

- 8 max. per 32 x 60 system. 18 max. per 56 x 120 or 72 x 180 system.
- Four DTMF, loop start line circuits.
- Install in any trunk slot for 32 x 60 system.
- Install in any trunk slot except the first in 56 x 120 and 72 x 180 systems.

DTS-4TRK-A (P/N 88127) Trunk Circuit PCB

- 8 max. per 32 x 60 system. 18 max. per 56 x 120 or 72 x 180 system.
- Four ground or loop start trunks, either dial pulse (DP) or DTMF signaling.
- Install in any trunk slot for 32 x 60 system.
- Install in any trunk slot except the first slot for 56 x 120 and 72 x 180 systems.

DTS-VAU-A (P/N 88210) Voice Announcement PCB

- One per system - optional.
- Use when system requires:
 - Personal Greeting Announcements
 - Voice Prompt Messages
 - ACD "All Agents Busy" Announcement
- Also contains two DTMF receivers used for DISA and/or ASI (P/N 89748) devices.
- Install in any trunk slot in the Main CEU except the first.

DTS-OPA/VAU-A (P/N 88211) Voice Announcement PCB

- One per system - optional. Install in place of VAU PCB.
- Provides Operator Assistance (OPA)
- Has all the other capabilities of the VAU PCB.

Note: The last two trunk ports of the trunk slot used must be programmed for -6db gain (in the QE command) when installing a DTS-VAU-A or OPA/VAU PCB. Installation of a DTS-VAU-A or OPA/VAU PCB (in the Main CEU only) reduces the number of line circuits by four.

DTM-MLU-A Main Link Unit PCB

(See Detail D, page 9)

- (P/N 88175 - For 32 x 60 System Only)
- (P/N 88178 - For 56 x 120, 72 x 180 Systems Only)
- Limit one per system.
- Has two DTMF receivers for DISA and ASI P/N 89748.
- Install the MLU-A only in last trunk slot of the main CEU.

Note: When installing a DTS-MLU-A PCB in the last slot of the CEU, the first two trunk ports (29-30) must be programmed for -6db gain the QE command.

DTS-Single Channel T1 (P/N 88111)

DTS-Dual Channel T1 (P/N 88112)

T1 Trunk PCB

- One per system - optional.
- Requires ONYX IV 2.1 software or higher.
- Single Channel (channel A) replaces 4 analog trunks but provides up to 24 digital T1 trunks.
- Dual Channel (channel A & B) replaces 4 analog trunks but provides up to 48 digital T1 trunks.
- Install in the first slot of the main CEU only.

Note: Refer to ONYX IV T1 Trunk PCB Instructions (P/N N1850TTK01) for further information.

Detail A
DTS-SIM-A PCB (P/N 88275)

Main CEU - strap M straight across
 Expansion CEU #1 - strap S1 straight across
 Expansion CEU #2 - strap S2 straight across

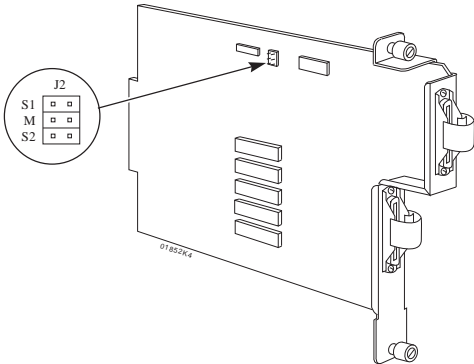

Detail C
DTS-MEM-B PCB (P/N 88132)

Strap jumpers J1, J2, J3 in the 2-3 position

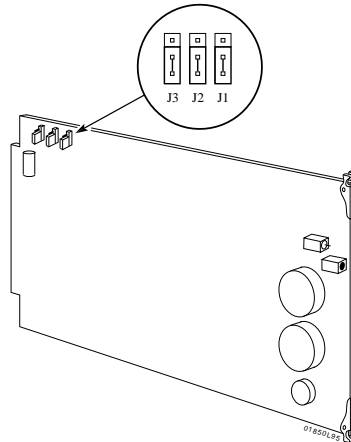

Detail B
DTS-MEM-A PCB (P/N 88130)

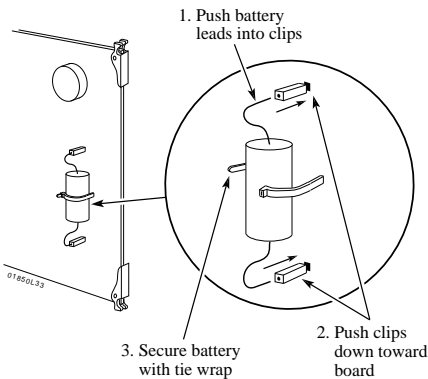

Detail D
**DTS-MLU-A PCB (P/N 88175 for 32 x 60),
 (P/N 88178 for 56 x 120 and 72 x 180 only)**

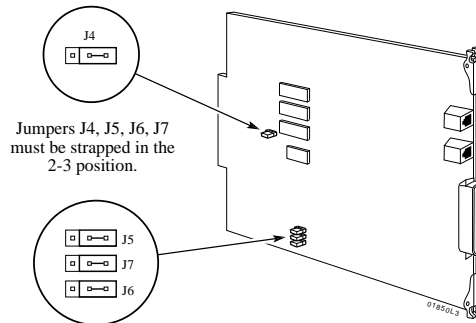

Detail E

For These Systems...

| Use These Components... | ONYX II 32 x 60 | ONYX III 32 x 60 | ONYX III 56 x 120 | ONYX III 72 x 180 | ONYX II 56 x 120 | ONYX II 72 x 180 | ONYX IV 56 x 120 | ONYX IV 72 x 180 |
|---------------------------------------|-----------------|------------------|-------------------|-------------------|------------------|------------------|------------------|------------------|
| DTS-SIM-A (P/N 88275) | - | - | 2 | 3 | 2 | 3 | 2 | 3 |
| DTS-SIM Cable (P/N 88276) | - | - | 1 | 3 | 1 | 3 | 1 | 3 |
| Software Cartridge (P/N 88385) | - | - | 2 | 3 | - | - | - | - |
| Software Cartridge (P/N 88285) | - | - | - | - | 2 | 3 | - | - |
| Software Cartridge (P/N 88484) | - | - | - | - | - | - | 2 | 3 |
| Software Cartridge (P/N 88281) | 1 | - | - | - | - | - | - | - |
| Software Cartridge (P/N 88381) | - | 1 | - | - | - | - | - | - |
| System Documentation (P/N N1853KIT01) | - | - | 1 | 1 | 1 | 1 | 1 | 1 |
| System Documentation (P/N N1850KIT01) | 1 | 1 | - | - | - | - | - | - |
| Or Use Interlink Sales Kit | - | - | 88300 | 88301 | 88200 | 88201 | 88305 | 88306 |

0188622A

4. POWERING UP THE SYSTEM

1. Plug in the power cord and turn on the power supply of the main CEU.
2. Check the power supply LEDs in each CEU.

| Function | Indication |
|---|------------|
| POWER ON (Green) | ON |
| D.C. FAULT (Red) | OFF |
| READY (Green) | OFF* |
| CHARGE (Amber) | OFF* |
| FAULT (Red) | OFF* |
| * These LEDs are only on the PSU-A and PSU-D. | |

Note: The FAULT (Red) LED is ON when the battery is disconnected from the PSU-A/D power supply.

3. To measure power supply voltages, insert the black meter lead (common) into the COMMON test point.

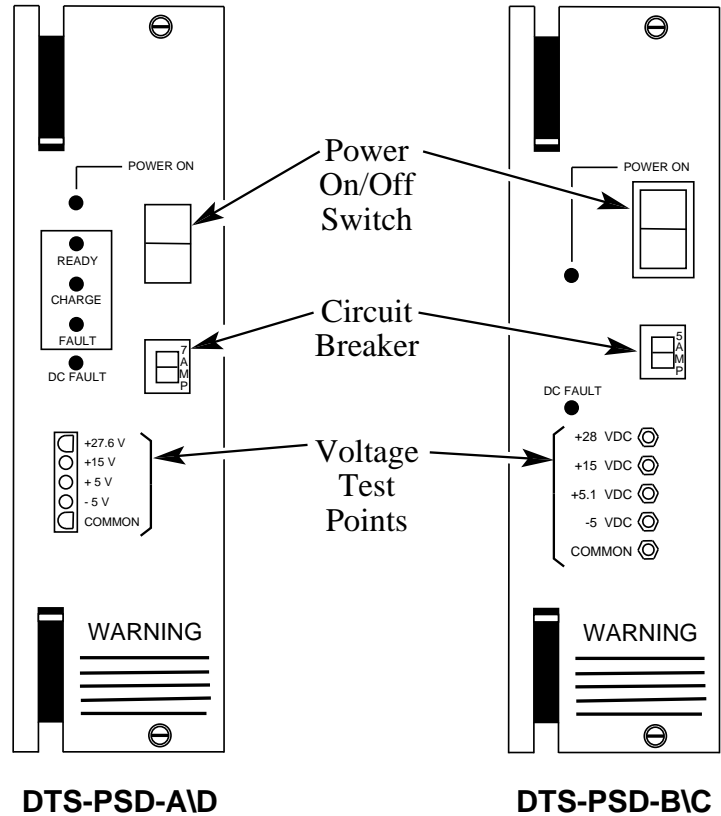

| Test Point | Measurement | |
|------------|-------------|--------------------|
| +27.6V | +27.6 Vdc | ±0.1 Vdc-(PSU-A/D) |
| +28V | +28.0 Vdc | ±2.0 Vdc-(PSU-B/C) |
| +15V | +15.0 Vdc | ±0.75 Vdc |
| +5V | +5.1 Vdc | ±0.1 Vdc |
| -5V | -5.0 Vdc | ±0.25 Vdc |

4. After a few seconds, check the status LEDs on the following:

DTS-HCPU-
DTS-MEM-
DTS-4LNU-
DTS-4TRK-
DTS-VAU or OPA/VAU
DTS-STI

5. Repeat Steps 1, 2, 3 and 4 for each expansion CEU.

DTS-CPU-A/B

If LED is Then...

- FLASHING . . . CPU is working
- OFF CPU not working
- ON CPU processors running
- OFF CPU processors not running

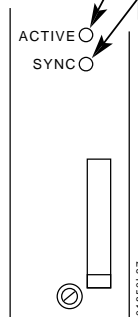

DTS-VAU-A & OPA

If LED is PCB is...

ON Working
OFF Not working

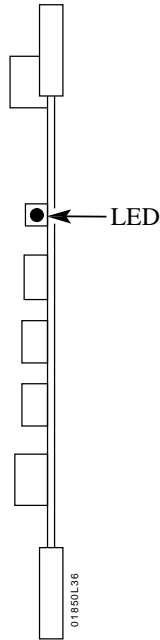

DTS-4LNU-B

DTS-4TRK-A

If LED is Then...

ON Line is busy
OFF Line is idle
FLASHING . . . Line is ringing in

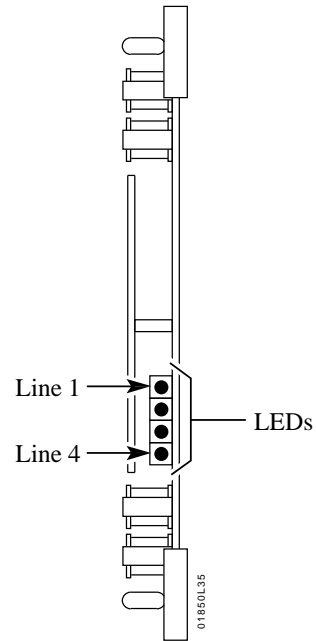

If LED is PCB is...

FLASHING . . . Working
OFF Not working

DTS-MEM-A

DTS-MEM-B

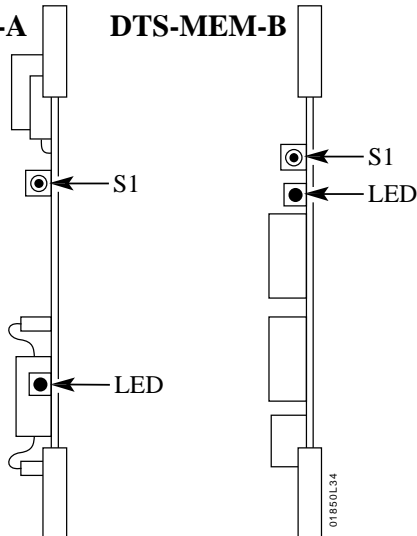

Note: The system runs sidetone and loop current tests on all DTS-4LNU- and DTS-4TRK- circuits when powering up. LED's on these PCB's light while the tests are being run.

Note: Pressing the S1 button on the DTS-MEM-B in the main cabinet initiates a warm reset to the system and this will disconnect all calls.

Note: Pressing the S1 button on DTS-MEM-A/B in an Expansion CEU initiates a local reset to the Expansion CEU.

5. INSTALLING TELEPHONES

To install key telephones:

1. Plug each key telephone, DSS console, ASI device, or STI into a modular jack.
2. Make a test call. In the standard program:
 - Attendant keyset is 300.
 - DSS Console is 302.
 - Any telephone (except Attendant Console) works in any port.
 - Each 30-button set has lines 1-24 on programmable keys.
 - Each 10-button set has lines 21-24 on programmable keys.
 - Keys on attendant's keyset flash and ring for all incoming calls.
 - Keys on other extensions flash for incoming calls but do not ring.
 - All lines are loop start DTMF signaling.

If the telephone doesn't function, check the voltages at the modular jack.

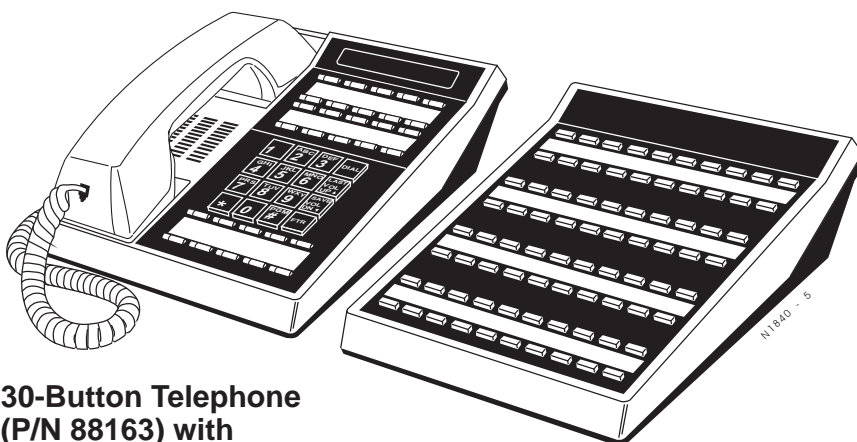

30-Button Telephone (P/N 88163) with DSS Console (P/N 88555)



10-Button Telephone Console (P/N 88155)



Electronic Single Line Telephone (P/N 88250)

| Meter Leads | Terminal | Voltages |
|---------------|----------|----------|
| Black lead to | GRN | +27 Vdc |
| Red lead to | BLK | |
| Black lead to | RED | +27 Vdc |
| Red lead to | YEL | |
| Black lead to | GRN | 0 Vdc |
| Red lead to | RED | |
| Black lead to | BLK | 0 Vdc |
| Red lead to | YEL | |

* All voltages $\pm 5\%$

Refer to the Parts List on page 22 and 23 for additional ONYX telephones.

To install an Attendant Console for ONYX IV (at extension 300):

- Plug the power supply (if applicable) into the console.
- Plug the console into a dedicated 120 V AC receptacle.
- Assign the Attendant Console circuit type 06 in E2- Circuit Type.
- Plug the

console line cord into the console modular jack.

Note: To customize Attendant Console operation or program additional consoles, refer to the Attendant Console feature in the Software Manual.

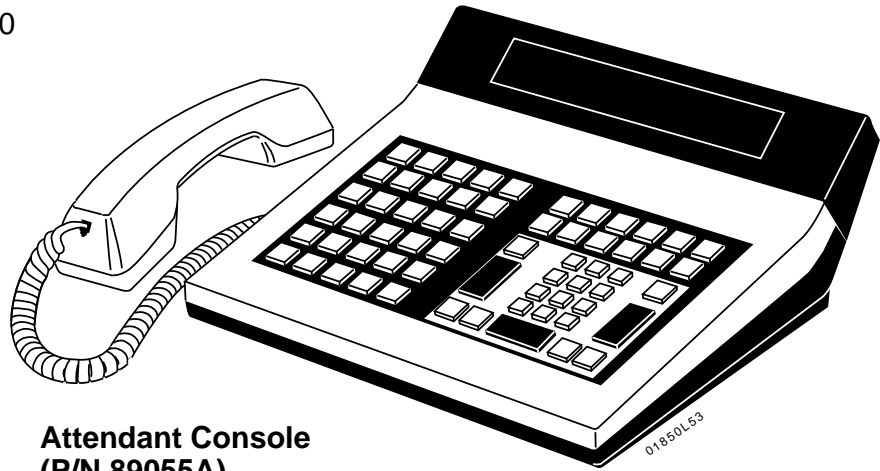

Attendant Console (P/N 89055A)

Analog Station Interface (ASI) (P/N 89748 and P/N 89749)

Note: ASI P/N 89748 requires DTMF receivers in a DTS-VAU-, DTS OPA/VAU or a DTS-MLU-PCB. To test the system DTMF receivers, refer to the IT option.

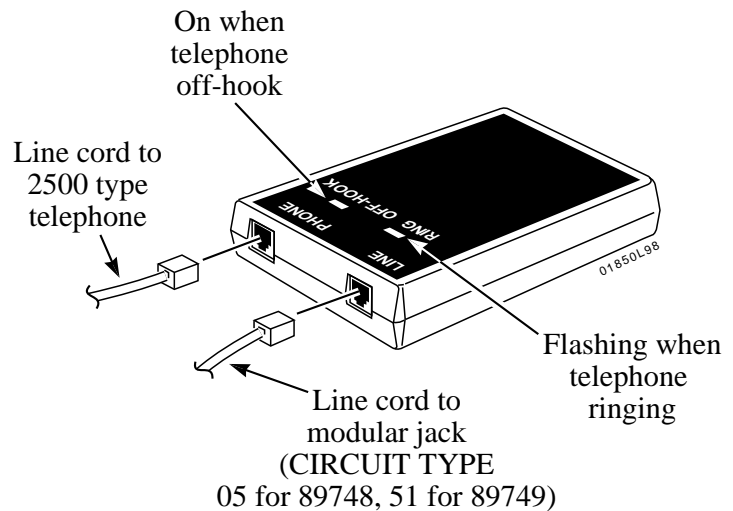

5. INSTALLING TELEPHONES (Cont'd)

To install a keyset bridged to a Data Module for Simultaneous Voice and Data:

1. Select an adjacent even and odd numbered port (e.g., 312 and 313).
2. Cross connect the "B" pair leads on the even numbered port to the "B" pair leads on the next adjacent odd numbered port.
3. Connect station cable from the odd numbered port to the Data Module's modular jack.
4. Plug the modular jack into the Data Module's SYS connector.
5. Plug the keyset into the Data Module's TEL jack.
6. Refer to the Data Products Manual (P/N N1850DMG01) for programming and operation.

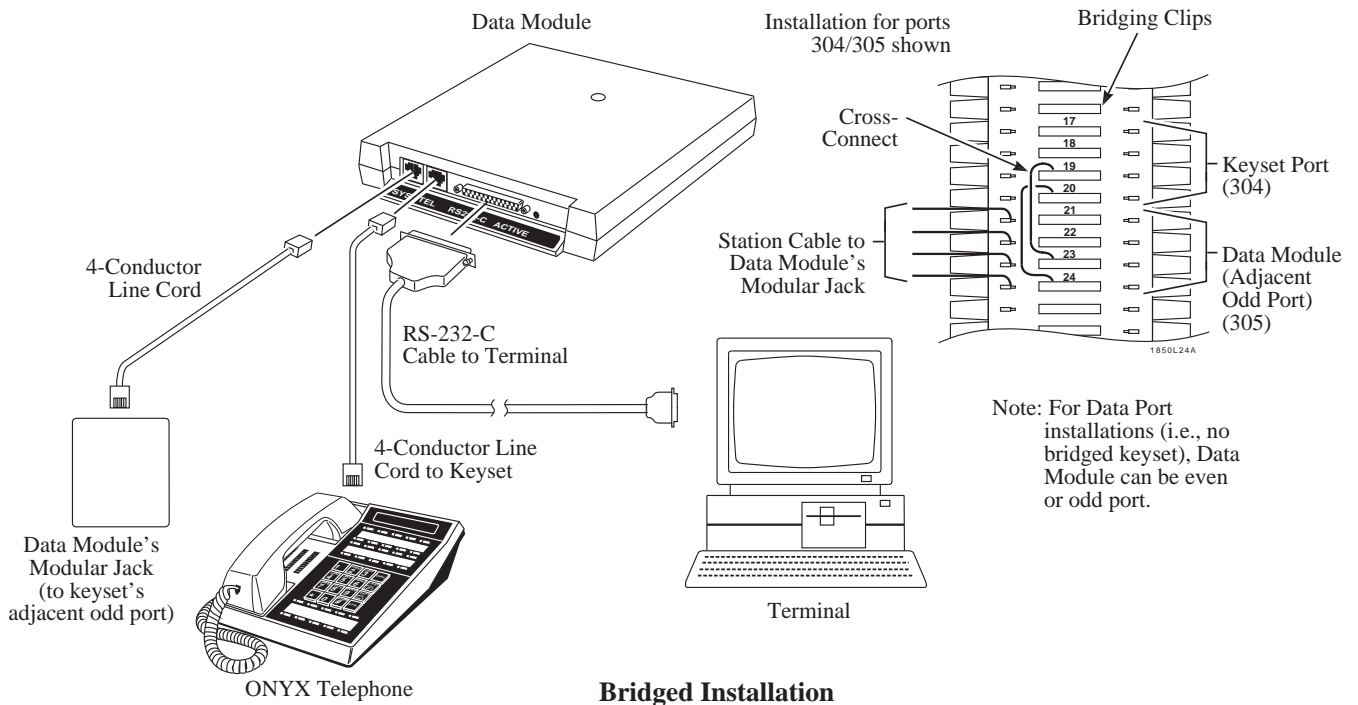

Bridged Installation

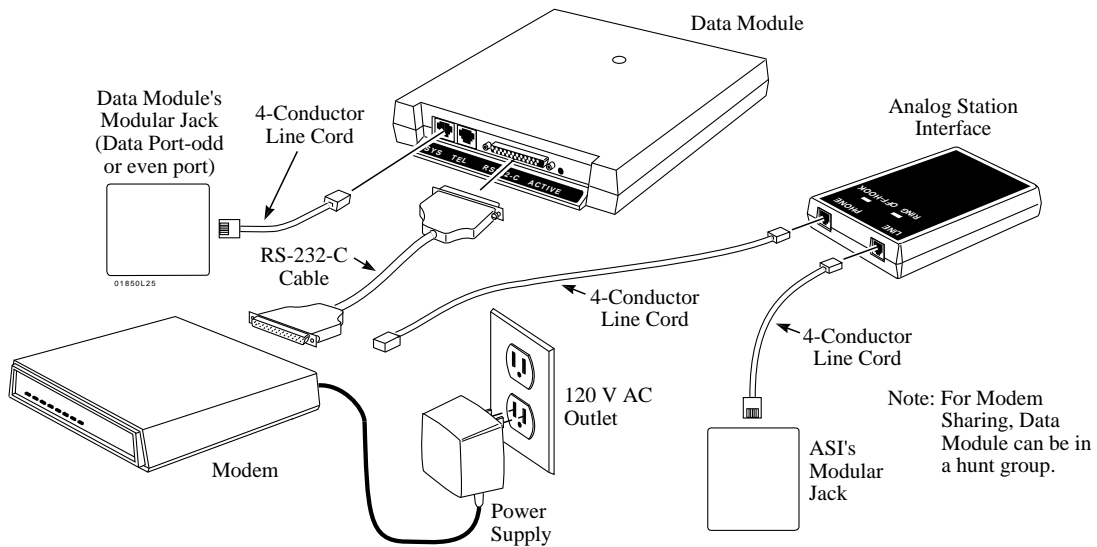

Modem Installation

**Integrated Voice and Data
Simultaneous Transmission of Voice and Data
Over 2-Pair Station Wiring**

5.

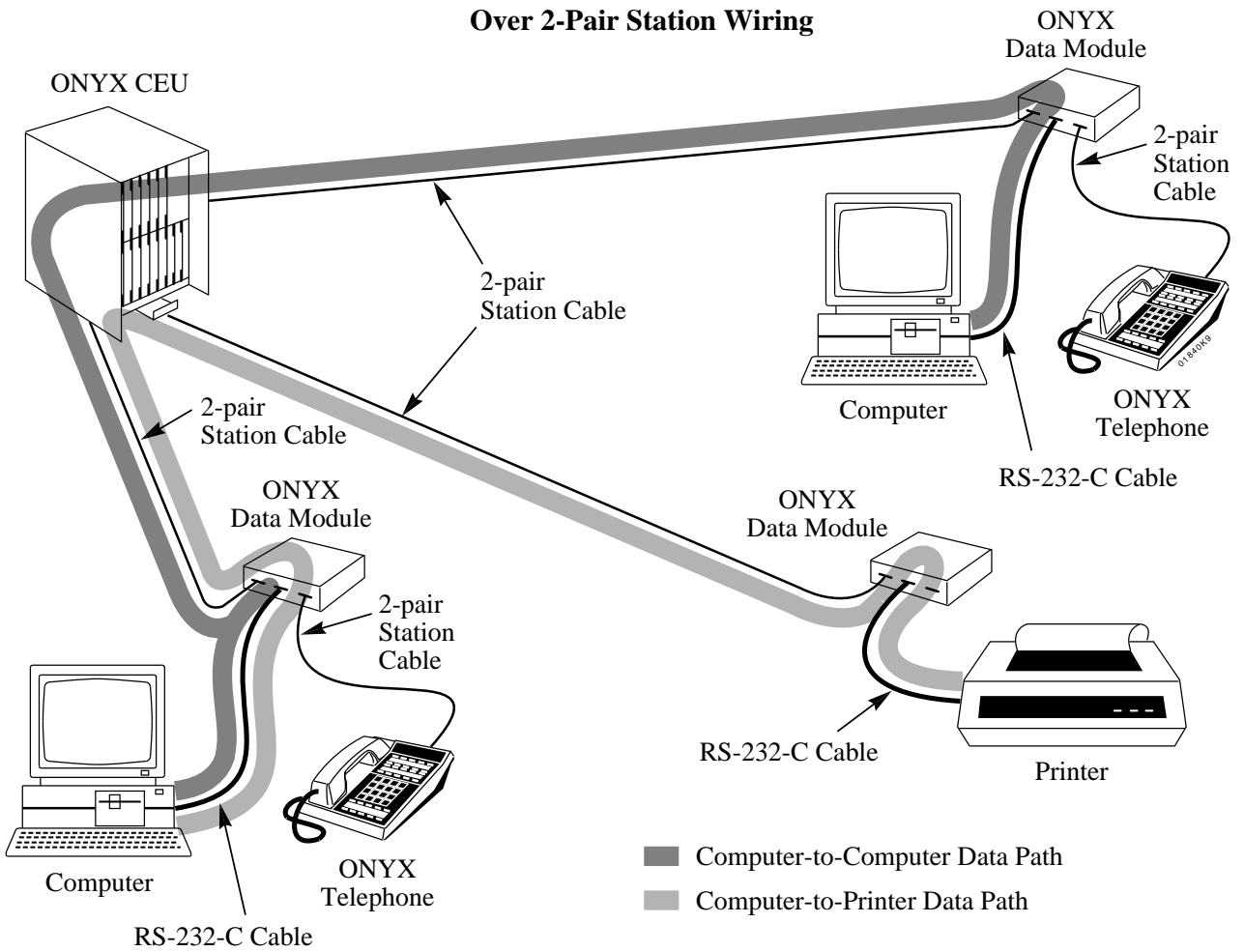

For additional installation instructions for data products, refer to the Data Products Manual (P/N N1850DMG01).

6. PROGRAMMING TERMINAL AND MODEM CONNECTIONS

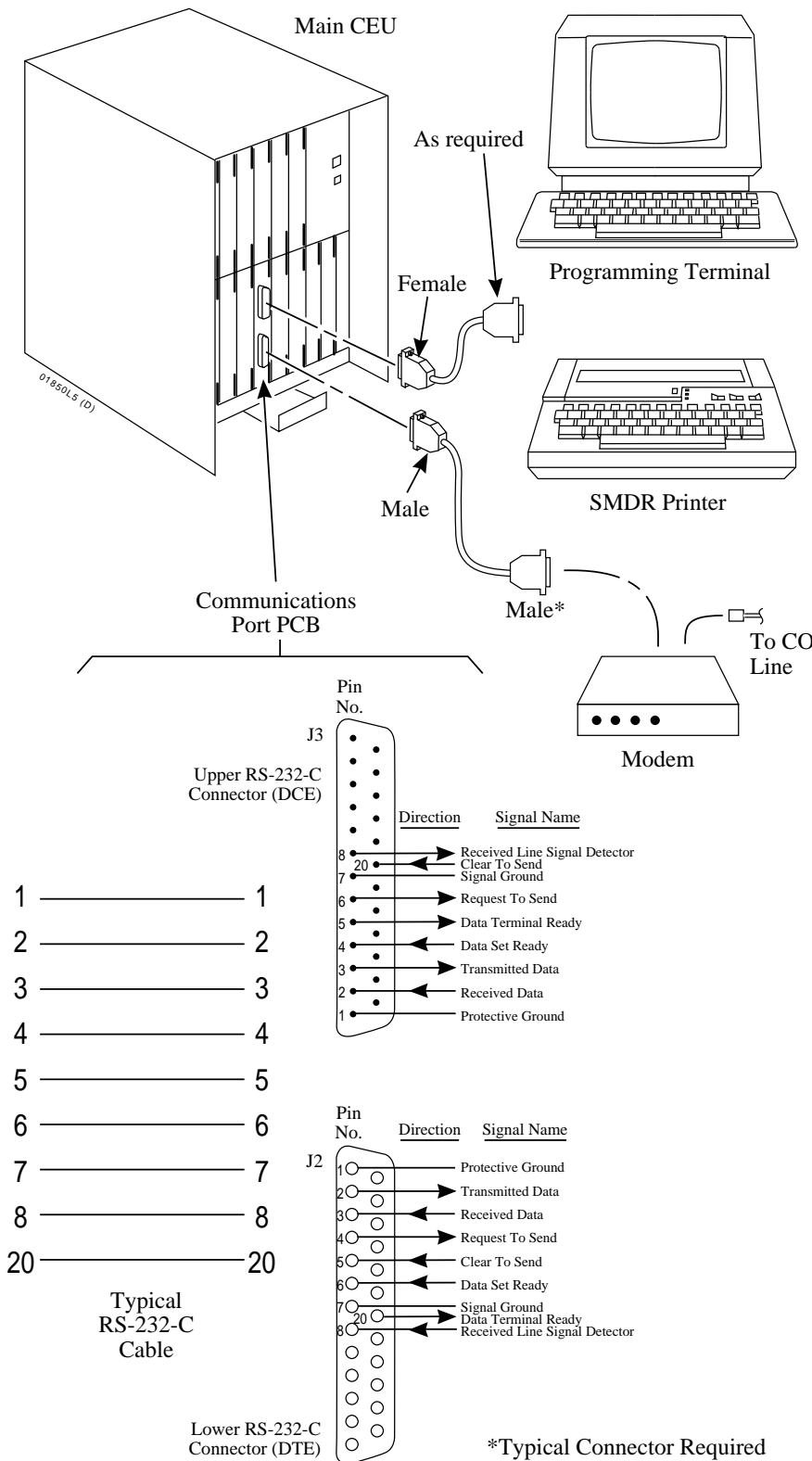

Connecting the programming terminal or modem.

1. Connect the programming terminal or SMDR printer (DTE device), to the upper port on the Communications Port PCB. Use standard RS-232-C cables (with ends as shown).
2. For Remote Maintenance and Automatic Fault Reporting, connect the modem (DCE device) to the lower port on the Communications Port PCB. Use standard RS-232-C cables (with ends as shown).
3. The port speeds **must** match the devices connected to them. The default speed of either device is 1200 baud, 8 bits, 1 stop bit, no parity. Refer to the Software Manual (J option).

To change the baud rate from the attendant's station (station 300):

1. Lift handset.
2. Press INTERCOM. Listen for dial tone. INTERCOM lights.
3. Press PGM/#, 0.
4. Dial 1 to change modem (lower) port.
... or ...
Dial 2 to change terminal (upper) port.
5. Dial 0-5 to select baud rate.

0 = 300 baud
 1 = 1200 baud
 2 = 2400 baud
 3 = 4800 baud
 4 = 9600 baud
 5 = 19.2K baud

6. Hang up.

7. INSTALLING MUSIC SOURCE, EXTERNAL PAGING AND CONTROL RELAYS

Connecting a music source:

Background Music and Music on Hold may share the same source, or use separate sources.

1. Using station cable, connect the music source audio input to an unused line circuit on the Line Block. Refer to Tables 2-5.
2. The music source must be compatible with system specifications.
3. Program the line circuit for BGM and/or MOH (QM and E2 options). Refer to the Software Manual.

Connecting an external page output:

1. Using station cable, connect page amplifier audio input to an unused line circuit (4 max.) on the Line Block. Refer to Tables 2-5.
2. The page amplifier must be compatible with system specifications.
3. Program the line circuit for paging (QM and E2 options). Refer to the Software Manual.

Connecting control relays:

Control relays are normally open. You may program these relays (2 per DTS-TRPT PCB in the Main CEU) to close for station ring, night ring, or external page.

Relays typically control external ringers or page amplifiers.

1. Connect the control relay outputs to the control inputs on the device (CT1/CR1-CT4/CR4) in the Main CEU only. Use standard station cable. Refer to Tables 2-5.
2. The controlled device must be compatible to system specifications.
3. Program the control relay activation (CT1/CR1-CT4/CR4) in the QM option. Refer to the Software Manual.

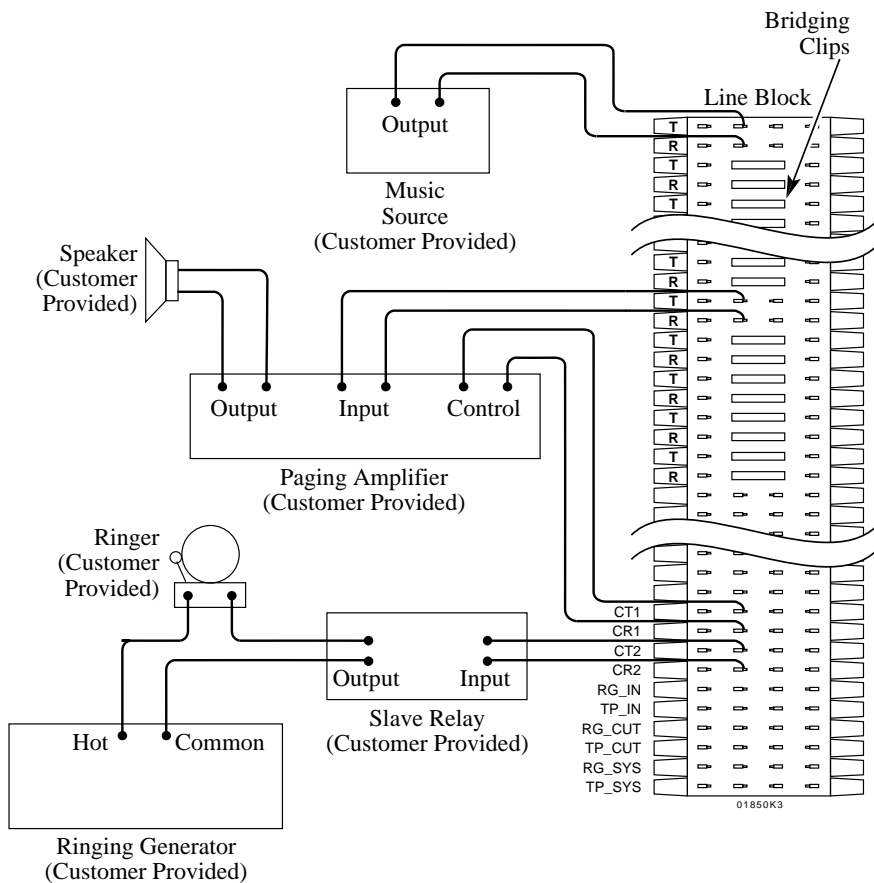

6.

7.

8. INSTALLING POWER FAILURE TELEPHONES

One power failure relay is provided per DTS-TRPT. One line per DTS-TRPT can be connected to a single line set for power failure operation. During a power failure, calls on the line ring the single line set. Use cross-connect wire for power failure connections. Refer to Table 2-5.

To install power failure operation:

1. Remove bridging clips on the power failure line.
2. Connect T and R (telco side) to TP__IN and RG__IN (customer side).
3. Connect TP__SYS and RG__SYS (customer side) to T and R (customer side).
4. Connect TP__CUT and RG__CUT (customer side) to T and R on the power failure telephone's modular jack.
5. For ground start lines, connect a ground wire to the modular jack. Select a ground that reliably starts the line.

Refer to the manufacturer's instructions when connecting power failure telephones.

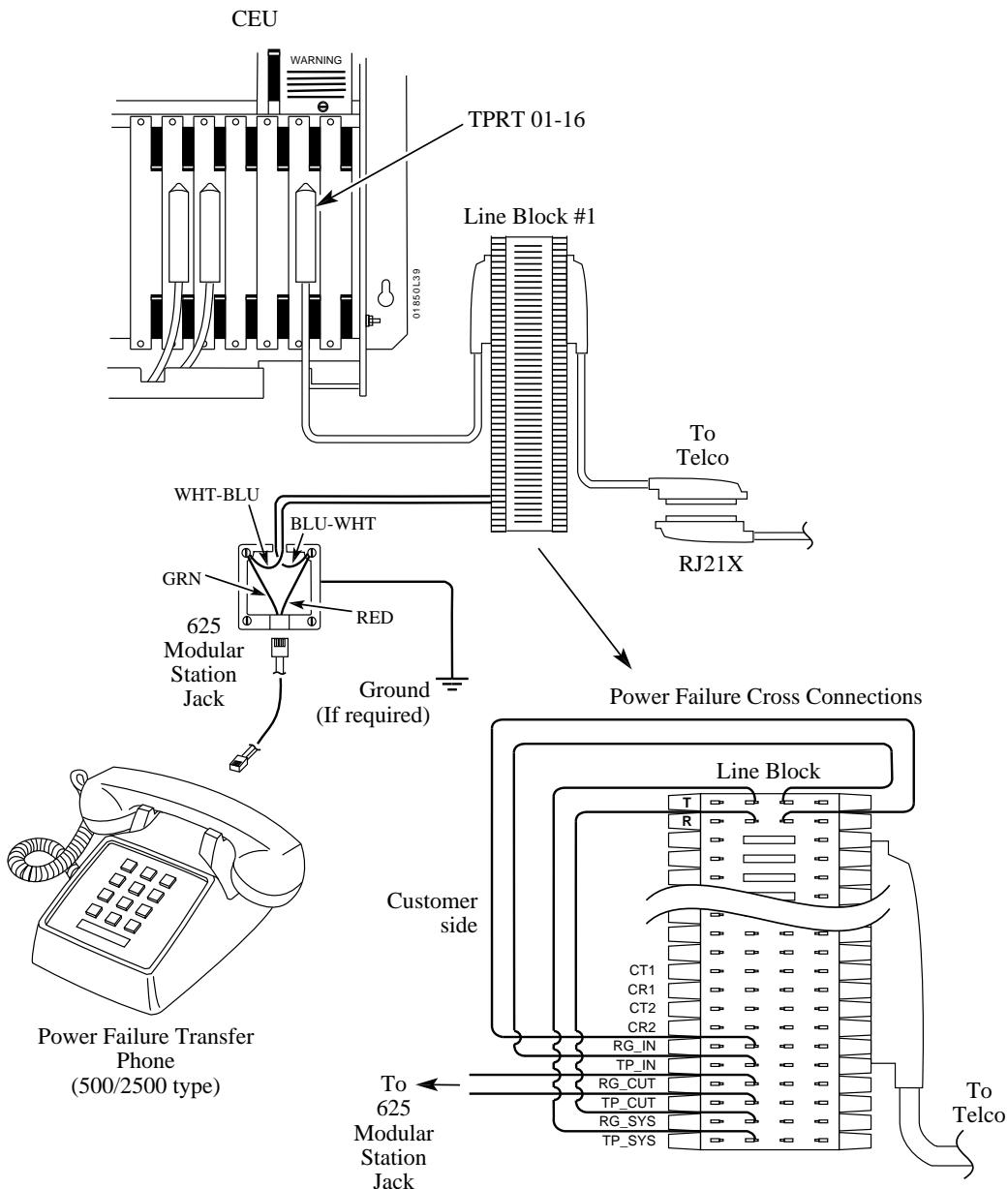

9. INSTALLING THE DUAL OPX/ASI MODULE (P/N 88750)

The Dual OPX/ASI Module connects to the even (lower) numbered port of adjacent even and odd numbered station ports. The module uses **both** extension positions (e.g., 304 and 305 or 306 and 307). The even port must be the lowest numbered port in the pair. Each Dual OPX/ASI module has two integral DTMF receivers and is intended for DTMF signaling only.

Ground the Dual OPX/ASI Module:

1. Connect a 14 AWG insulated stranded wire from the Dual OPX/ASI Module to a known earth ground.

Connecting the Dual OPX/ASI Module to your system:

1. Using a four-conductor modular line cord, connect the STA jack on the Dual OPX/ASI Module to a 625

2. Run station cable from the modular jack to the station block and connect as shown in the illustration below. You can use any adjacent ports, not just the pair shown in the illustration.
3. With a short length of cross-connect wire, cross-connect the adjacent port B pairs.

Connecting the Dual OPX/ASI Module to the telco OPX block:

1. Using four-conductor modular line cords, connect the OPX1 and OPX2 jacks on the Dual OPX/ASI Module to 625 type modular jacks.
2. Run station cable from each of the modular jacks to the telco OPX Block. Punch down the circuits according to the layout of your OPX block.

Programming the Dual OPX/ASI Module:

1. For terminal programming, set E2- Circuit Type = 51 for both circuits.

OR

For telephone programming, set Program 14 Extension Circuit Type = 51 for both circuits.

2. For each device connected to the Dual OPX/ASI Module, set the flash timer to 600-750 ms.

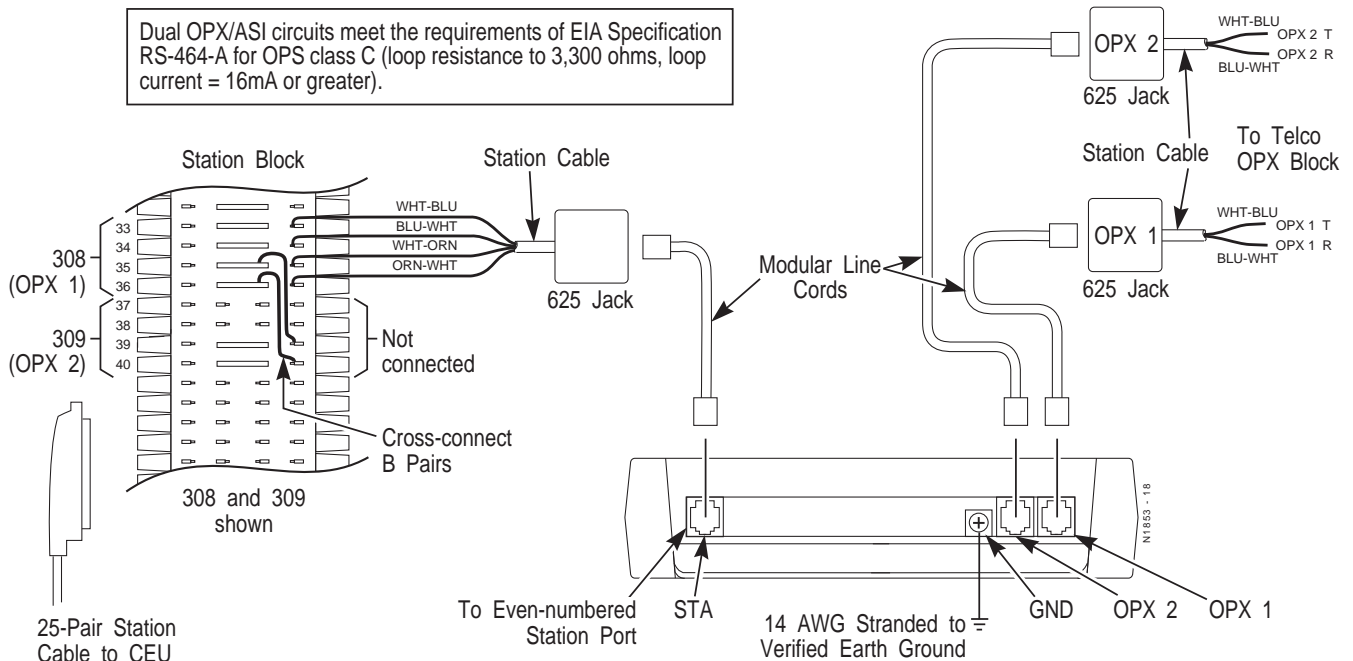

8.

9.

10. SPECIFICATIONS

CEU Specifications:

| | Lines | Stations |
|--|-------|----------|
| Main CEU - 32 x 60 system | 32 | 60 |
| Main CEU - 56 x 120 and 72 x 180 systems | 28 | 60 |
| Expansion CEU #1 | 28 | 60 |
| Expansion CEU #2 | 16 | 60 |

Installation of BGM, MOH, and each external page zone require one line circuit. Installation of each DTS-STI requires two station ports (2 max. for 32 x 60 system, 4 max. for 56 x 120 and 72 x 180 systems).

System Capacity:

| | |
|--|---|
| Power Failure Cut-Through Circuit | 2 (1 per DTS-TRPT) (32 x 60 systems) 6 (1 per DTS-TRPT) (56 x 120/72 x 180 systems) |
| Talk Timeslots (Intercom /lines) | 128 (32 x 60 system) 255 (56 x 120 and 72 x 180 systems) |
| DTMF Tone Duration (manual dial) | 256 ms on/128 ms off |
| DTMF Tone Duration (Speed Dial) | 128 ms on/128 ms off |
| Internal Page Zones | 7 (and All Call) |
| External Page Zones | 3 (and All Call) |
| External Control Relay Circuits | 4 per system maximum 2 per TRPT (Main CEU only) |
| Special Trunk Interface Units: | 2 per system max. (32 x 60 system) 4 per system max. (56 x 120 and 72 x 180 systems) |
| - OPX/DID Circuits | 16 (8 per DTS-STI) (32 x 60 system) 32 (8 per DTS-STI) (56 x 120 and 72 x 180 systems) |
| - Tie Lines | 14 (7 per DTS-STI) (32 x 60 system) 28 (7 per DTS-STI) (56 x 120 and 72 x 180 systems) |
| Consoles (56 x 120 and 72 x 180 systems) | 4 per system maximum |

Electrical Specifications:

AC Input:

95-135 V AC @ 47-64 Hz
Dedicated 15 A circuit
One dedicated circuit required for each Attendant Console (PBX only)

Power Requirements:

PSU-A/C 280 Watts maximum
PSU-B 180 Watts maximum
PSU-D 435 Watts maximum

Heat Dissipation (Nominal):

PSU-A/C 431 Btu/h
PSU-B 125 Btu/h
PSU-D 740 Btu/h
BBU 96 Btu/h

Fusing:

PSU-A/C 7 Amp circuit breaker
PSU-B 5 Amp circuit breaker
PSU-D 10 Amp circuit breaker
BBU 15 Amp slow-blow fuse:

Grounding Requirements:

Copper wire, continuous No. 14 AWG or larger

Battery Backup:

Install only the following Nitsuko approved batteries:
Eagle Picher CFMP12V33
Powersonic PS12400
Yuasa NP38-12

Batteries for the BBU are not provided by Nitsuko. Both batteries must be from the same manufacturer.

External Control Relay Contact Rating:

Max. Load: 60 mA @ 30 Vdc

10 mA @ 90 Vac

Maximum Initial Contact Resistance:

50 m Ohms

External Zone Paging:

Output Impedance: 600 Ohms

Max. Output: +dBm (1.09 Vac)

Background Music/Music on Hold:

Input Impedance: 600 Ohms

Maximum Input: -10 dBm (244 mVac)

Cable Requirements:**CEU to CEU:**

The DTS-SIM (system interlink) cable length is nine feet. This cable must be used to link CEUs for 56 x 120 and 72 x 180 systems.

From CEU to ASI:

Four-conductor (two-pair twisted station cable)

2,000 feet w/No. 24 AWG

2,500 feet w/No. 22 AWG

Key Equipment:

Four-conductor (two-pair twisted station cable)

2,000 feet w/No. 24 AWG

2,500 feet w/No. 22 AWG

From ASI to OPX device:

100 feet using 22 AWG

Use 25-pair cables with Type 57 female connectors to connect to DTS-12SCU PCBs.

Use 25-pair cables with Type 57 male connectors for DTS-TRPT PCBs.

Use multiconductor "riser cables" to an Intermediate Distribution Frame (IDF) when required.

Mechanical Specifications:

Common Equipment Unit

Height

21 1/8"

Width

13 13/16"

Depth

17 1/8"

Weight

54 lb.

Battery Backup Box

53.7 cm

35.1 cm

43.5 cm

24.6 kg

9"

24"

9 1/2"

20 lb.

Telephones

22.9 cm

70.0 cm

24.2 cm

9.1 kg

3 1/2"

7 1/2 "

10 1/8"

2.7 lb

8.9 cm

19.1 cm

25.8 cm

1.3 kg

NOTE: Weight of CEU is with all PCBs installed. Weight of Battery Backup Box is without batteries.**Environmental Specifications:**

Refer to the Standard Practices Manual (P/N N2710STD01)

FCC Registration Information:

Model:

DTS

Manufacturer:

Nitsuko America

Reg. Jack:

USOC RJ21X

FCC Part 15 Registration:

Class A

Sample FCC Registration Number:

32 x 60 system Key: BJ286G-16856-KF-E -

56 X 120 and 72 x 180 systems Key: 1ZDUSA-65327-KF-E

32 x 60 system Hybrid: BJ286G-10094-MF-E

56 x 72 and 72 x 180 systems Hybrid: 1ZDUSA-65329-MF-E

Ringer Equivalence Number:

(REN)-2.5B

Refer to the label on the right side of the CEU for FCC Registration number.

11. PARTS LIST

| Description | Part Number |
|--|-------------|
| Common Equipment | |
| CEU-D 32/60 Common Equip. Cabinet | 88100D |
| PSU-A 60 Station Power Supply w/Battery Backup Charger (use w/ p/n 88107) | 88108 |
| PSU-C 60 Station Power Supply | 88106A |
| BBK-A Battery Back-Up Kit (Includes 1 - 15324, 1 - 88199) | 88107 |
| 4 LNU-B Line Card B | 88110B |
| 12 SCU-A Station Card | 88120 |
| COM-A RS232 Communications Card | 88125A |
| 4TRK-A Trunk Card | 88127 |
| MEM-A Memory Card | 88130 |
| MEM-B Memory Card | 88132 |
| TRPT-A Trunk Protect (16 circuits) | 88135 |
| HCPU-A Central Processor | 88340 |
| STI-B Special Trunk Interface | 88147 |
| MLU-A Main Link Card (32 x 60 system only) | 88175 |
| MLU-A Main Link Card (56 x 120, 72 x 180 system only) | 88178 |
| VAU-A Digital Voice Announcer Card | 88210 |
| OPA/VAU-A Digital Operator Assistance/Voice Announcer Card | 88211 |
| SIM-A System Interlink Card | 88275 |
| SIC System Interlink Cable | 88276 |
| Software | |
| Onyx II 32 x 60 Software Cartridge | 88281 |
| Onyx II 72 x 180 Key Software Cartridge | 88285 |
| Onyx III 32 x 60 Software Cartridge | 88381 |
| Onyx III 72 x 180 Hybrid Software Cartridge | 88385 |
| Onyx IV 72 x 180 Software Cartridge | 88484 |
| ONYX VS/II/III/IV Back-up and On-line Software Diskette (5 1/4" Disk) | 88217 |
| T1 Equipment | |
| DTS T1 1-Port Card | 88111 |
| DTS T1 2-Port Card | 88112 |
| DTS SIM-A Card T1 Software Update | 88279 |
| DTS 1-Port T1/CSU Kit (Includes: 1 - 88111, 1 - 85950, 1 - 85951, 1 - 85957) | 88310 |
| DTS 1-Port T1/DSU Kit (Includes: 1 - 88111, 1 - 85955, 1 - 85957) | 88311 |
| DTS 2-Port T1/CSU Kit (Includes: 1 - 88112, 2 - 85950, 2 - 85951, 2 - 85957) | 88320 |
| DTS 1-Port T1/Quad DSU Kit (Includes: 1 - 88111, 1 - 85956, 1 - 85957) | 88312 |
| T-Serve II CSU | 85950 |
| T-Serve II Power Supply | 85951 |
| CSU/DSU DB 15M - DB 15F Cable | 85952 |
| CSU/DSU RJ48 - DB 15 Cable | 85953 |
| Data Smart DSU Add/Drop Unit | 85955 |
| Quad Datasmart DSU | 85956 |
| CSU/DSU Cable Assembly Kit (Includes: 1 - 85952, 1 - 85953) | 85957 |
| Station Equipment | |
| 30-Button Standard Telephone (Black & White) | 88260B |
| 30-Button Standard Telephone (Black) | 88360 |
| 30-Button Handsfree Telephone (Black & White) | 88261B |
| 30-Button Handsfree Telephone (Black) | 88361 |
| 30-Button LCD Display Telephone (Black & White) | 88263B |
| 30-Button Handsfree LCD Display Telephone (Black) | 88363 |
| 30-Button Handsfree LCD Display Telephone w/Dual LEDs (Black & White) | 88264 |
| 30-Button Handsfree LCD Display Telephone w/Dual LEDs (Black) | 88364 |
| Digital Single Line Telephone (Black & White) | 88250 |
| Digital Single Line Telephone (Black) | 88350 |
| Onyx IV Attendant Console (requires cartridge, p/n 88484) | 88269 |
| Other Station Equipment | |
| 80-Button DSS Console (Black & White) (utilizes 2 ports) | 88555 |
| 80-Button DSS (Black) (utilizes 2 ports) | 88355 |

| | |
|--|---------|
| ASI - Analog Station Interface (single port w/DTMF receiver) | .89749 |
| Dual Port ASI (dual port w/DTMF receivers) | .88750 |
| Wall/Desk Mounting Kit | .88179A |

Data Products

| | |
|--|---------|
| Data Module | .88400 |
| Data Module Kit (Includes: 12 - 88400) | .88400K |
| Dataport PCB | .88460 |
| Modem Pooling PCB | .88465 |
| Mini Data Unit | .89408 |
| Min Data Unit Power Supply | .89409 |
| DCE-DCE Adaptor | .89079 |

Replacement Parts

| | |
|---|-----------|
| 20-Button Module | .88171 |
| 20-Button Module w/Display | .88176 |
| Handsfree Module | .88170 |
| Handset Coil Cord 6' | .88185-6 |
| Handset Coil Cord 6' (Black) | .85326 |
| Handset Coil Cord 9' | .88185-9 |
| Handset Coil Cord 9' (Black) | .85323 |
| Handset Coil Cord 13' | .88185-13 |
| Handset Coil Cord 13' (Black) | .85324 |
| Telephone Label Insert | .88157 |
| Tractor Feed Telephone Label Inserts for 100 Stations | .88267 |
| DTS DSS Insert (Pkg of 20 forms/4 strips per form) | .88557 |
| Telephone Directory Tray (Less Card) | .89788 |
| Directory Tray Card | .88159 |
| K1 Handset w/6' Coil Cord (Black) (Hearing Aid Compatible) | .86245H |
| K1 Handset & Cord (Hearing Aid Compatible) | .89085H |
| K2 Handset & Cord (Hearing Aid Compatible) | .88185H |
| Line Cord 4 Cond. 7' | .89086 |
| Line Cord 4 Cond. 14' | .89087 |
| Line Cord 4 Cond. 25' | .89088 |
| Onyx DSS Plastic Lens | .88558 |
| Onyx Plastic Designation Strip | .88258 |
| Plain Address Card (replaces 89788 and 88159) | .88158 |
| Rubber Feet - Set of 2 | .88259 |
| Station Number Shield | .86145 |
| Battery Box | .15324 |
| Battery Box Cable | .88199 |
| Ext. Battery Cable OIU (spare for P/N's 88146, 88147 and 88122) | .88148 |

11.

Installation Equipment

- Plywood Backboard ¹
- 66M1-50 connecting block(s) ¹
- 25-pair cable(s) ¹
- 22/24 AWG 4-conductor twisted-pair station cable ¹
- Cross-connect wire ¹
- Bridging clips ¹
- Module jack (1 per station) ¹
- Module line cords (1 per CO line) ¹
- Ground wire (1 per CEU) ¹
- RJ11C Telco interface (1 per CO line) ¹
- AC surge protector (1 per CEU) ¹

¹ Item not supplied by Nitsuko America

NEC

NEC America, Inc., Corporate Networks Group
4 Forest Parkway, Shelton, CT 06484
Tel: 800-365-1928 Fax: 203-926-5458
cng.nec.com

Other Important Telephone Numbers

| | |
|---|--------------|
| Sales: | 203-926-5450 |
| Customer Service: | 203-926-5444 |
| Customer Service FAX: | 203-926-5454 |
| Technical Service: | 203-925-8801 |
| Discontinued Product Service: | 900-990-2541 |
| Technical Training: | 203-926-5430 |
| Emergency Technical Service (After Hours) | 203-929-7920 |

(Excludes discontinued products)

NEC

NEC America, Inc., Corporate Networks Group
4 Forest Parkway, Shelton, CT 06484
TEL: 203-926-5400 FAX: 203-929-0535
cng.nec.com

December 1994
Printed in U.S.A.



N1852INS03